

Environmental Welding: The Friction Stir Welding

Selim Sarper Yilmaz¹, Bekir Sadık Ünlü², İbrahim Aydın²

*1Celal Bayar University, Vocational High School, Department of Machinery,
45020, Manisa, Turkey*

*2Celal Bayar University, Faculty of Engineering, Mechanical Engineering,
45040, Manisa, Turkey*

E-mails: *selim.yilmaz@cbu.edu.tr, bekir.unlu@cbu.edu.tr,
ibrahim.aydin@cbu.edu.tr*

Abstract

In this study, microstructural and mechanical properties of pure aluminum joined by friction stir welding using different parameters were investigated. Hardness, tensile, bending and impact mechanics tests were applied to the welded samples. In addition, optical and SEM tests were carried out. The effects of the welding progress rate on the microstructure and mechanical properties were investigated in these materials. Then, the optimal conditions for friction stir welding were determined for pure aluminum.

Keywords: Friction stir welding, aluminum alloy, microstructure, mechanical properties.

1. INTRODUCTION

Aluminum metal and its alloys are economical and attractive material due to their superior mechanical properties. These features include the appearance, lightness, ease of production, physical and mechanical properties and corrosion strength. Aluminum is known for two mechanical properties; namely, lightness and corrosion resistance. The weight of aluminium is approximately a third of the same volume steel, aluminum, copper or brass and its specific gravity is 2.7 g/cm³.

Aluminum has an excellent corrosion resistance against the atmosphere, water, salt water, oil and many chemicals. In

addition, electrical and thermal conductivity of aluminum is superior. In addition, the strengths of some aluminum alloys are higher than strength of structural steels (ASM Metals Handbook, 1979).

Friction stir welding (CCT) is a solid-state welding technique developed by the Welding Institute (Cambridge, United Kingdom) in 1991 and is used for the combination of the non-ferrous metals and alloys. Although friction stir welding can be used to combine a large number of materials, the first studies and the industrial interest have focused on the combination of aluminum alloys. Friction stir welding has become an important and rapidly developing welding technique in combining these alloys (Boz and Kurt, 2004; Fonda, Bingert and Colligan, 2004; Somasekharan and Murr, 2004; Meran, 2006)

In friction stir welding, tools which are cylindrical, rotating, inexhaustible, and hard, has got a tip in the center and is composed of a shoulder. The tip of the tools is firmly immersed in between the two workpieces to be welded and brought forehead to forehead firmly. During the welding, while the tip is going forward in a rotational movement, the shoulder moves towards the welding in contact with the upper surface (Meran, 2006; Ericsson, 2005; Smith, Hinrichs; Crusan and Leverett 2003; Butlerworth-Heinemann, 2001; Staron, Koçak, Williams and Wescott, 2004).

Friction stir welding of welding connections found in the welding region is a typical form of onion rings and weld metal, as the format consists of many variables. This format depends on the type of alloy being welded and the parameters of welding process (Özsoy and Kaluç, 2002).

The position of the half-circles on the surface of the tool during rotation and forward movement provides necessary heat for the welding and pushes hot metal on the surface and appears to stay on the surface. The continuous nature of welding provides the consistency of semi-circular rings and the distance between the rings is equal to the distance the tool travels during one rotation. The material is pushed towards the sides and back in a semi-circular ring during each rotation of the tool. There is more mixing near the upper surface. All these results lead the researchers to the idea that the process mentioned is an extrusion process (Mert and Kaluç 2003). Although the main material or the material resistant to heat is far from the welding point, they are affected by the thermal cycle of the process. But this does not affect the microstructural or mechanical properties (http://tech.plymouth.ac.uk/sme/UoA30/Weld_Microstructure.PDF).

The objectives of this study are to investigate mechanical properties of pure Al, to study the hardenability of welding region and the region under the heat effect, to further investigate internal structures of these regions and the resistance value of welded parts.

2. EXPERIMENTAL STUDIES

Plates of 5 mm x 110 mm x 300 mm size were processed using an universal milling machine. Afterwards, 8 mm thick base material was placed on the milling table. After clamping the plates to be joined on the metal sheet base, the material

was ready for welding process. The mechanical characteristics of the materials used in the experiments are summarized in Table 1.

Table 1. Mechanical properties of materials used in the experiments

Material	Tensile Strength (MPa)	Break Elongation (%)	R_{0.2} Yield Strength (MPa)	Hardness (HV)
Pure	105	40	25	20

In the experiments, tip geometry of the material and revolution per minute was kept constant, but, travelling speed of the tip was varied (Table 2).

Table 2. Friction stir welding parameters

Material	Spindle Speed (rpm)	Traveling Speed (mm/min)
Pure	1250	20
		40
		63

After cleaning the surface of the plates to be joined with the help of bind mold head to head, friction stir welding was successfully realized. There was neither distortion nor deformation of welded plates after joining process.

Tensile tests were applied to determine the maximum stress values of plates of welded joints. The tensile samples prepared in accordance with DIN 50109 as shown in Figure 1 were processed perpendicularly to the welding direction of the sheets in a CNC milling machine. The tensile tests were carried out at a cross head speed of 2 mm/min using an Universal Testing Machine (AG- 50kNG Shimadzu Autograph, Japan). True stress and strain curves were determined by computer connected to the device. Threepoint bend tests at 180° were conducted at a bending speed of 10 mm/min.

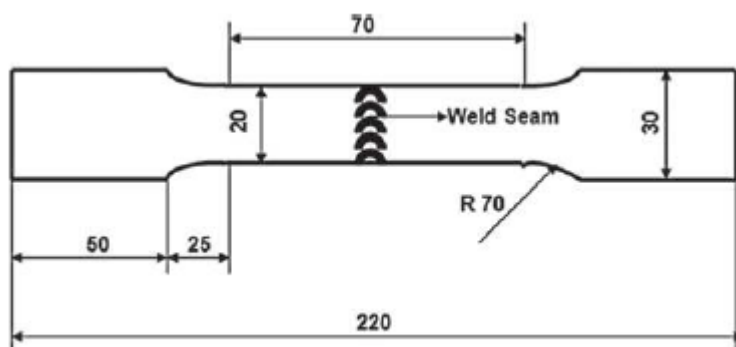

Fig.1. Samples prepared for tensile test and subsequent measurements

For optical microscope examinations, samples from the base material and welding region were taken out, before and after welding process. Samples measuring 10 x 20 x 5 mm were cut. The surfaces of the samples were polished by means of abrasives having a 220, 400, 600, 800 and 1200 grid, respectively. After the process of the last polishing the materials with 10 micron alumina polish, the sample surfaces were etched in Keller solution with 2 ml hydrofluoric acid (HF), 10 ml nitric acid (HN03) and 88 ml water immersion for 12 seconds. Henceforth, the structural changes occurring in the junction area were determined. In the analysis of samples, an optical microscope (Nikon Eclipse U50, Japan) was used.

3. RESULTS AND DISCUSSION

3. 1. Mechanical Properties

Figure 2 shows the microhardness results of pure aluminum groups.

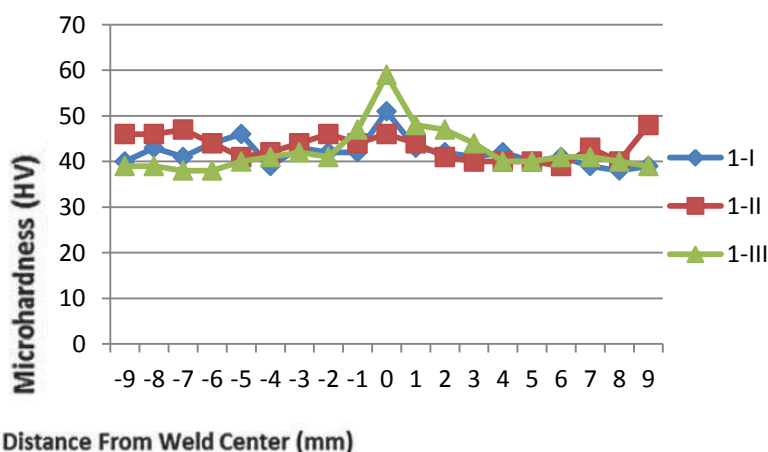

Fig.2. Microhardness distribution of pure aluminum

When hardness of all samples was examined, four different regions of hardness distribution were found to change significantly. Hardness values of the samples joined by friction stir welding were higher than those of the base material.

The samples broke in the HAZ (heat affected zone) region adjacent to the weld seam, as the tensile tests were applied to the welds. This region was identified as the thermo-mechanically formed region under the influence of the welding heat.

The results of the tensile tests are given in Figure 3.

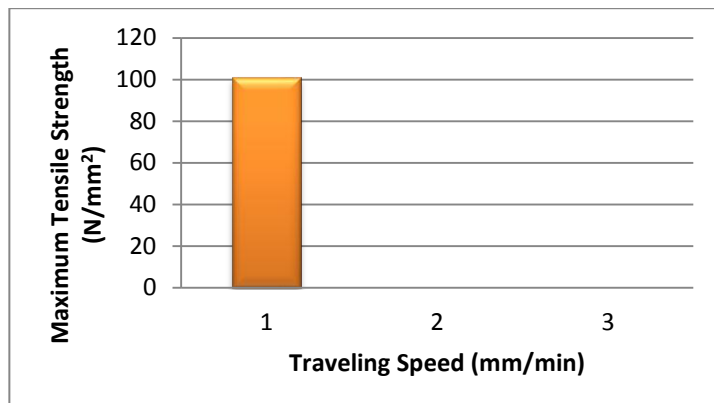

Fig.3. Maximum tensile strength distributions for pure aluminum

The tensile strength of pure aluminum decreased with an increase in welding speed. The reason was that low heat input of HAZ due to increasing travelling speed caused large decreases in the HAZ width, the samples experienced fewer necks which could cause decreases in tensile strength. This was not the case for pure aluminum. The highest tensile strength for pure aluminum was observed at the 20 mm/min travelling speed.

As a result of bending tests, no failure occurred in the weld region. The results of bending test are given in Figure 4.

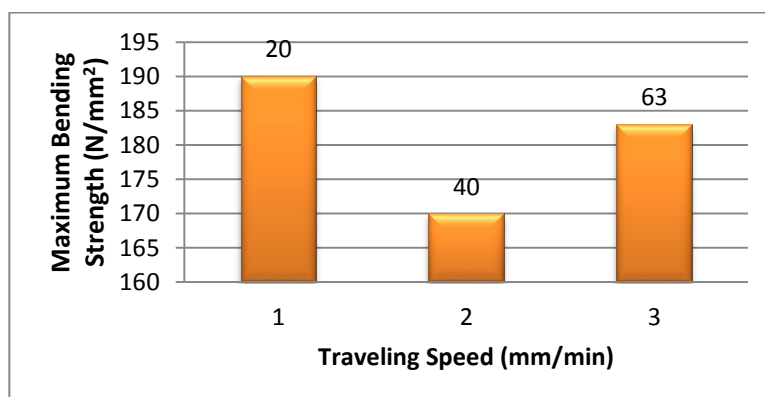

Fig.4. Aluminum bending test results for pure aluminum

Charpy test results of pure aluminum welds are given in Figure 5.

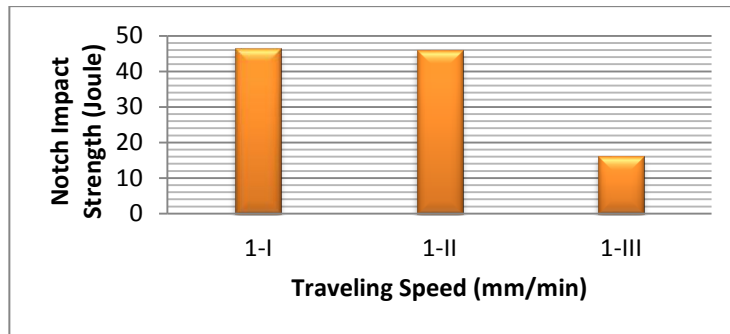

Figure 5. Charpy test results for pure aluminium

For the Charpy notch impact test, a standard test device with a capacity of 300 Joule was used. A 2 mm deep notch with a 45° angle was opened in the middle of the specimens which measured 55 x 10 x 5 mm due to the dimensions of the friction stir welded plates.

3. 2. Microstructure Properties

The schematic cross-section of a typical friction stir weld shows four distinct zones which are illustrated in Figure 6, as reproduced from another study. Friction stir welding is a solid state welding method which produces joints below the melting temperature. Friction stir welding produces a very narrow heat affected zone compared to other welding methods, because not very high temperatures are involved in this process.

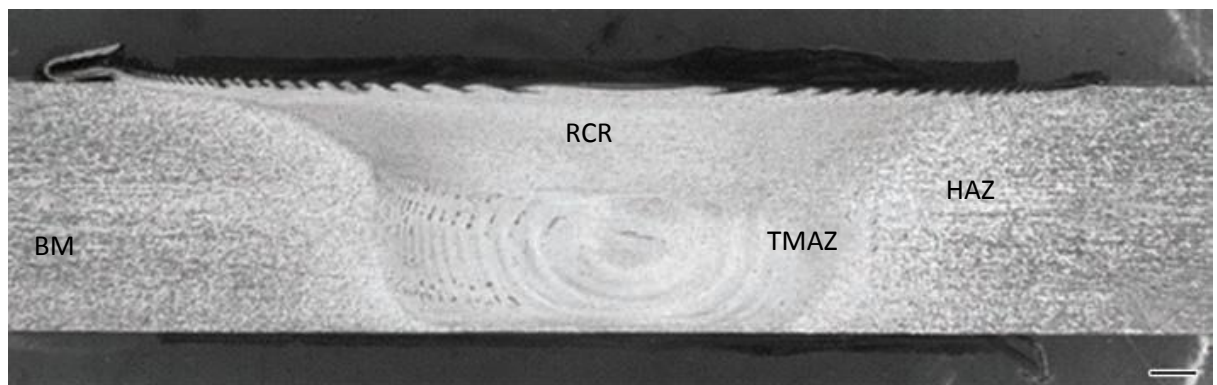

Fig. 6 Macrostructure of the friction stir welding

These areas are the dynamical recrystallized region (RCR), the thermo-mechanical affected zone (TMAZ), the heat affected zone (HAZ) and the base material (BM). The following four different regions were thus determined throughout the experiments:

- A: base material
- B: heat affected zone (HAZ)
- C: thermo-mechanical affected zone (TMAZ)
- D: dynamically recrystallized zone (DXZ)

In the DXZ, the grains become smaller as a result of severe deformation and extrusion, whereas in thermo-mechanical affected zone (TMAZ), the grains were observed to grow gradually. The fine-grained structure of the dynamical recrystallized zone (DXZ) contributed to strength and hardness improvement after welding. The cause of changes in the structures of grain is associated with the heat of friction.

When the number of revolutions was kept constant and the traveling speed was increased, in the buffer zone, the widths of the mix of bands gradually increased. This case can be related to the amount of material transported per unit time and increasing travelling speed.

This region of intense plastic deformation and high friction temperature is called as "dynamical recrystallized zone" or "welding center". Dislocation density is lower and thinner in this region and it is composed of oriented grains. In the friction stir welding applications of similar types of alloys, this region resembles a pool of onion rings. The TMAZ zones are shown in the Figures 7, 8.

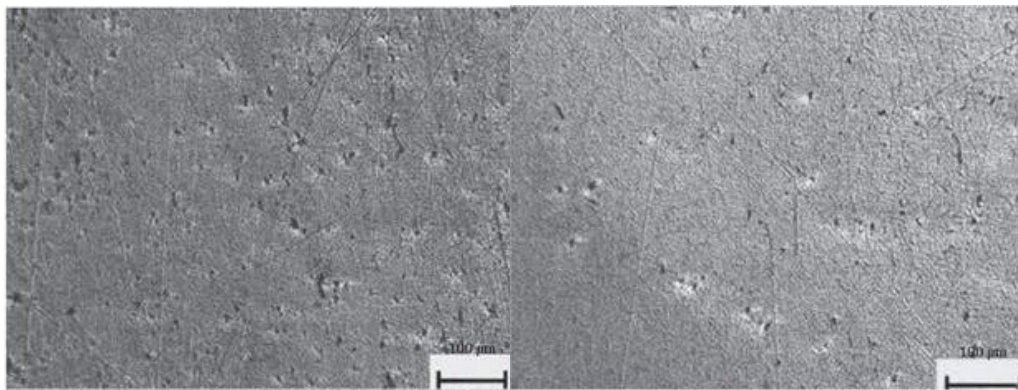

Fig.7. The microstructural zones of pure aluminium after welding

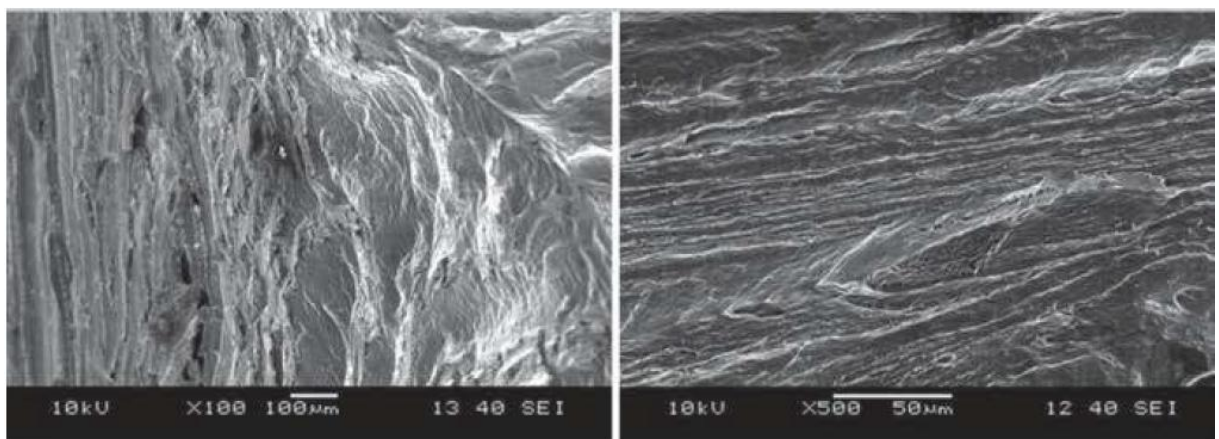

Fig. 10. Fracture surfaces pure aluminium

4. CONCLUSIONS

The following conclusions can be drawn from the present investigations of pure aluminium types:

Micro-structural analysis indicated an expansion in the size of the heat affected zone with reduced travelling speed.

In the dynamical recrystallized zone, the grains became smaller as a result of severe deformation and extrusion while in the thermo-mechanical affected zone, the grains were observed to grow gradually.

The travelling speed of 40 mm/min produced the best microhardness, bending, tensile and Charpy test results for all the samples studied, and thus, has to be regarded as the optimum travelling speed.

After complete bending, no microcracks were observed in the weld zones

REFERENCES

- ASM Metals Handbook(1979). Properties and Selection: Nonferrous Alloys and Pure Metals, American Society for Metals, Metals park, Ohio.
- BozA., KurtA.(2004). The influence of stirrer geometry on bonding and mechanical properties in friction stir welding process. *Materials and Design*(25), 343–347.
- FondaR. W., BingertJ. F., ColliganK. J.(2004). Development of grain structure during friction stir welding. *Scripta Materialia*(51), 243–248.
- SomasekharanA. C., MurrL. E.(2004). Microstructures in friction-stir welded dissimilar magnesium alloys and magnesium alloys to 6061-T6 aluminum alloy. *Materials Characterization*(52)49–64.
- MeranC.(2006). The joint properties of brass plates by friction stir welding. *Materials and Design*(27)719–726.
- Ericsson M.(2005). Fatigue strength of friction stir welded joints in aluminum. Ph.D Thesis, Royal Institute of Technology. Sweden.
- SmithC. B., HinrichsJ. F., CrusanW. Leverett(2003). FSW stirs up welding process competition. *Forming & Fabricating*(2)25–31.
- David J. E.,(2001). *Ship Construction*, 5th Edition, Butterworth-Heinemann, India
- StaronP., KoçakM., WilliamsS., WescottA(2004). Residual stress in friction stir-welded Al sheets, *Physica B*(350) 491-493.
- ÖzsoyM., KaluçE.(2002). Sürtünen eleman ile birleştirme kaynağının esasları, *Mühendis ve Makine Dergisi* (513)21-35 (in Turkish).

3rd International Symposium on Sustainable Development, May 31 - June 01 2012,
Sarajevo

MertS.,KaluçE. (2003). Sürtünme karıştırma kaynağında kullanılan takımlardaki gelişmeler.TMMOB Makine Mühendisleri Odası Kaynak Teknolojisi IV.Ulusal Kongresi Bildiriler Kitabı, 103-115 (in Turkish)

http://tech.plymouth.ac.uk/sme/UoA30/Weld_Microstructure.PDF